

24-12-2019

Roll No.

Total Pages : 3

BT-1/D-19

31020

ENGINEERING DRAWING AND GRAPHICS

Paper-ME-105 N

Group-(ii)

Time : Three Hours]

[Maximum Marks : 75

Note : Attempt *five* questions in all, selecting at least *one* question from each unit.

UNIT-I

1. Draw the projections for the below points. Take a single reference line. The distance between the projectors is 40 mm.
 - (a) Point 'A' is 20 mm above HP and 30 mm in front of VP.
 - (b) Point 'B' is 20 mm below HP and 40 mm behind VP.
 - (c) Point 'P' is 10 mm above HP and 30 mm Behind VP.
 - (d) Point 'C' is 45 mm below HP and 35 mm in front of VP.
 - (e) Point 'R' is 25 mm in front of VP and in HP. (15)

2. Top View of a 75 mm long line CD, measures 50 mm. End C is in HP and 50 mm in front of VP. End D is 15 mm in front of VP and it is above HP. Draw projections of CD and find angles with HP and VP. (15)

31020/800/KD/1721

[P.T.O.
24/12

UNIT-II

3. A regular hexagon of 25 mm side has its one edge on the HP. The surface of the plane is perpendicular to the VP and inclined at 40° to the HP. Draw the projections of the plane. (15)
4. A Pentagonal pyramid of base side 30 mm and axis length 60 mm is resting on HP on one of its triangular faces with its axis inclined at 35 degrees to VP. Draw its projections. (15)

UNIT-III

5. A hexagonal prism of base of side 30 mm and axis length 60 mm rests on one of its bases on the HP. It is cut by a plane perpendicular to the VP and inclined at 40° to the HP. The cutting plane bisects the axis. Draw its front and the sectional top views. (15)
6. Draw the development of the truncated hexagonal pyramid cut by an auxiliary cutting plane making an angle of 60° with HP, bisects the axis. With a 30 mm base side and 60 mm height, which is resting on its base in the HP such that an edge of the base is perpendicular to VP. (15)

UNIT-IV

7. Draw the front view, top view and side view of the following object : (15)

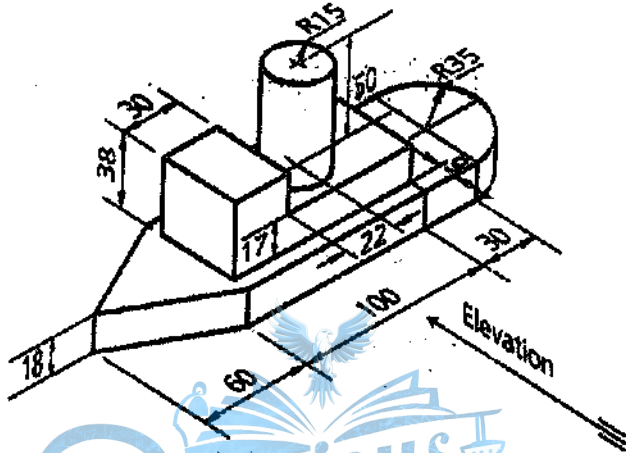

8. Describe the use of following commands in AUTOCAD using suitable examples :

- (a) Line.
- (b) Polygon.
- (c) Mirror.
- (d) Offset.
- (e) Fillet.

(15)