

Roll No. ....

Total Pages : 3

BT-I/D-18

**31041**

ENGINEERING GRAPHIC AND DRAWING

Paper : ES-109(A)

Group : I

Time : Three Hours]

[Maximum Marks : 75

Note : Attempt *five* questions in all, selecting at least *one* question from each unit.

**UNIT-I**

1. Draw a hypocycloid of a circle of 40 mm diameter which rolls inside another circle of 200 mm diameter for one revolution. Draw a tangent and normal at any point on it. 15
2. Construct a diagonal scale of R.F. = 3/100 to measure upto 5 metres, showing metres, decimetres and centimetres. Mark on it a length of 2.69 metres. 15

**UNIT-II**

3. The end E of a line EF, 80 mm long is in both the HP and the VP. The line is inclined at 35° to the HP and 40° to the VP. Draw its projections. Also locate its traces. 15
4. A Pentagonal pyramid of base side 30 mm and axis length 60 mm is resting on HP on one of its triangular faces with its axis inclined at 35 degrees to VP. Draw its projections. 15

### UNIT-III

5. A Cone of base diameter 50 mm and axis length 75 mm is resting on HP on its base. It is cut by a plane perpendicular to both HP and VP and is 10 mm to the left of the axis. Draw its top view, front view and true shape of the section. 15
6. A cone of base diameter 60 mm and height 70 mm is resting on its base on HP. It is cut by a plane perpendicular to both the HP and VP at a distance 15 mm to the left of the axis. Draw the development of the lateral surface of the right remaining portion. 15

### UNIT-IV

7. Draw the front view, top view and left side orthographic view of the following object : 15

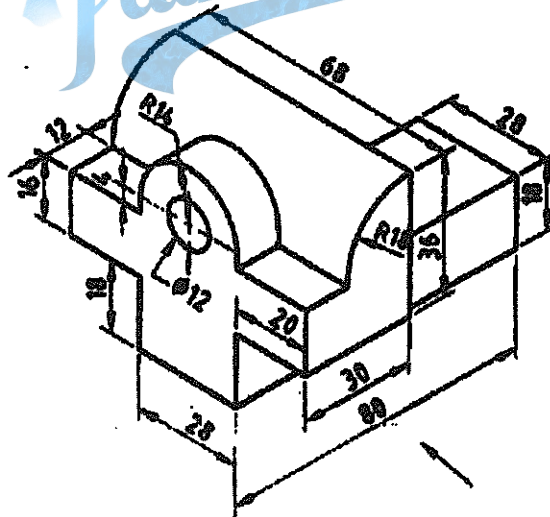

8. A sphere of radius 45 mm is kept in the centre of top face of frustum of a square pyramid of side 120 mm at the bottom, 80 mm at the top and having a height of 100 mm. Draw the isometric projection of the solid. 15
- 

